



**INSTALLATION AND OPERATION MANUAL  
5-TON PORTABLE AIR CONDITIONING &  
OPTIONAL HEAT PUMP**



260 North Elm St. Westfield, MA 01085  
Phone: 413-564-5520 Fax: 413-564-5815  
[www.koldwave.com](http://www.koldwave.com)

HPKW5N3AS  
REV — 01/24/20

# Koldwave

MODEL NO.	HKW30G3ATA60-TR		
SERIAL NUMBER	1610057		
VOLTS	208/230	PHASE	3
		CYCLE	60
COMP. LRA	351 EA	QTY	2
		RLA	53.6 EA
EVAP. MOTOR HP	15.0	FLA	35
COND. MOTOR HP	3.0 EA	QTY	2
		RLA	8.6 EA
ELEC. HEATER KW	60		
MCA	240.8		
MOP	250		
FACTORY CHARGE	R-410A	46 lb 0oz CKT1	
		46 lb 0oz CKT2	

TEST PRESS. HISIDE 500 PSIG - LOSIDE 250 PSIG  
 COMPRESSOR MOTOR AND FAN ARE THERMALLY PROTECTED  
 USE COPPER CONDUCTORS ONLY.  
 EXT. STATIC PRESS - 0.1 TO 1.0 IN. WC.  
 MAX OUTPUT AIR TEMP. 200 DEG. F OR LESS  
 MIN. CLEARANCE TO COMBUSTIBLE SURFACES - 0 IN

9CA-6242

## IDENTIFICATION OF YOUR UNIT

The Data Tag contains important information on how identify your Koldwave Unit. See Figure 1 for more information on locating tag.

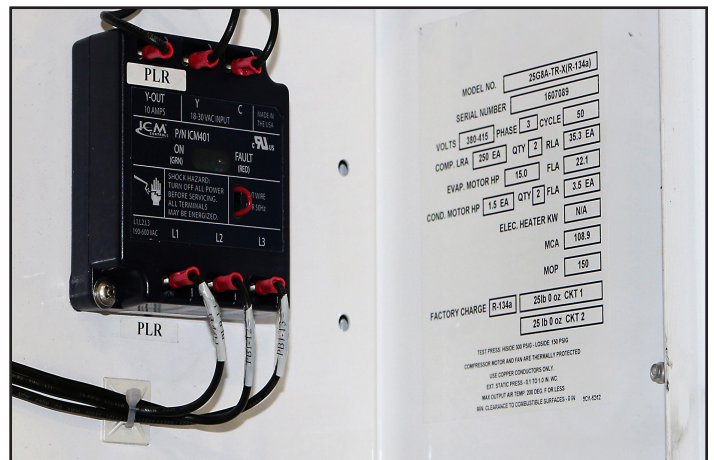

## TABLE OF CONTENTS

IDENTIFICATION OF YOUR UNIT .....	2
HPKW5N1AS* / HPKW5N*AS* – PRODUCT SPECIFICATIONS .....	4
HPKW5N3AS* / HPKW5N*AS* – PRODUCT SPECIFICATIONS .....	5
HPKW5N4AS* / HPKW5N*AS* – PRODUCT SPECIFICATIONS .....	6
UNIT INSPECTION .....	7
UNIT SETUP .....	7
DUCT CONNECTIONS .....	9
SYSTEM OPERATION .....	9
UNIT SAFETY DEVICES .....	11
UNIT COMPONENTS .....	12
REFRIGERATION SYSTEM COMPONENTS .....	12
ROUTINE MAINTENANCE .....	13
TROUBLESHOOTING GUIDE .....	17

### APPENDIX – DRAWINGS AND SCHEMATICS

Electrical Diagram W/O Heat .....	CA10296-A
Electrical Diagram W/ Heat .....	CA10262-A
Product Drawing .....	CA14085B

<b>WARNING: HIGH VOLTAGE – DISCONNECT POWER BEFORE SERVICING</b>	
<p><b>DISCONNECT POWER</b></p> <p>Failure to disconnect power before servicing could lead to severe personal injury or death.</p>	<p><b>RE-CONNECT ALL GROUNDS</b></p> <p>All parts of this product capable of conducting electrical current are grounded. If grounding wires, screws, straps, clips, nuts, or washers used to complete a path to ground are removed for servicing, they must be reconnected at their original location.</p>

# HPKW5N1AS\* / HPKW5N\*AS\* – PRODUCT SPECIFICATIONS

## COOLING MODE

Design Indoor Dry Bulb / Wet Bulb .....	80°F / 67°F
Design Outdoor Ambient Temperature .....	115°F
Total Cooling Capacity .....	BTU/HR 57,100
Sensible Cooling Capacity .....	41,200
Minimum Indoor Ambient Temperature .....	65°F
Design Return Air Dry Bulb .....	80°F
Design Return Air Relative Humidity .....	50%
Approximate Supply Air Flow Rate .....	2000 CFM
Rated External Static Pressure .....	1.5" w.c.

## HEATING MODE

Heating Capacity .....	BTU/HR 55,700
------------------------	---------------

## POWER REQUIREMENTS

Voltage / Phasing / Frequency .....	208-230/1/60
Minimum Circuit Ampacity Cool/Heat unit .....	(Amps) 55.8
*Dehumidification Option .....	(Amps) 116
Max Overcurrent Protection Cool/Heat unit .....	(Amps) 90
Max Overcurrent Protection *Dehumidification option .....	(Amps) 136

## COMPRESSOR

Type .....	5 Ton Scroll
Voltage / Phasing / Frequency .....	208-230/1/60
RLA .....	(Amps) 30.1
LRA .....	(Amps) 158

## CONDENSER BLOWER MOTOR

Horsepower .....	2
Voltage / Phasing / Frequency .....	208-230/1/60
FLA .....	(Amps) 11.2
Speed .....	RPM 3450

## EVAPORATOR BLOWER MOTOR

Horsepower .....	1.5
Voltage / Phasing / Frequency .....	208-230/1/60
FLA .....	(Amps) 6.8
Speed .....	RPM 3450

## REFRIGERANT

R-410 .....	6 lbs. 9 oz.
Low Pressure .....	70 PSIG Cutout 100 PSIG Reset
High Pressure .....	625 PSIG Cutout Manual Reset
Suction Operating Pressure .....	104 PSIG Low <sup>1</sup> 145 PSIG High <sup>1</sup>
Discharge Operating Pressure .....	290 PSIG Low <sup>1</sup> 600 PSIG High <sup>1</sup>
Subcooling .....	@ approx. 80 °F ambient 10-12°F <sup>1</sup>

## DIMENSIONS AND WEIGHT

Height/Width/Length .....	Refer to Product Drawing
Approximate Weight .....	710 lbs.*

\*Readings are dependent upon ambient conditions; numbers listed are approximate

## **HPKW5N3AS\* / HPKW5N\*AS\* – PRODUCT SPECIFICATIONS**

### **COOLING MODE**

Design Indoor Dry Bulb / Wet Bulb .....	<b>80°F / 67°F</b>
Design Outdoor Ambient Temperature .....	115°F
Total Cooling Capacity .....	BTU/HR..... 57,100
Sensible Cooling Capacity .....	BTU/HR..... 41,200
Minimum Indoor Ambient Temperature .....	65°F
Design Return Air Dry Bulb .....	80°F
Design Return Air Relative Humidity .....	50%
Approximate Supply Air Flow Rate .....	2000 CFM
Rated External Static Pressure .....	BTU/HR..... 1.5" w.c.

### **HEATING MODE**

Heating Capacity .....	BTU/HR..... 55,700
------------------------	--------------------

### **POWER REQUIREMENTS**

Voltage / Phasing / Frequency .....	208-230/3/60
Minimum Circuit Ampacity Cool/Heat Unit .....	(Amps)..... 36.7
*Dehumidification Option .....	(Amps)..... 87.1
Max Overcurrent Protection Cool/Heat Unit .....	(Amps)..... 40
*Dehumidification Option .....	(Amps)..... 90

### **COMPRESSOR**

Type .....	5 Ton Scroll
Voltage / Phasing / Frequency .....	208-230/3/60
RLA .....	(Amps)..... 20.5
LRA .....	(Amps)..... 155

### **CONDENSER BLOWER MOTOR**

Horsepower .....	2
Voltage / Phasing / Frequency .....	208-230/3/60
FLA .....	(Amps)..... 5.8-5.4
Speed .....	RPM..... 3450

### **EVAPORATOR BLOWER MOTOR**

Horsepower .....	1.5
Voltage / Phasing / Frequency .....	208-230/3/60
FLA .....	(Amps)..... 5.2-5
Speed .....	RPM..... 3450

### **REFRIGERANT**

R-410 .....	6 lbs. 9 oz.
Low Pressure .....	70 PSIG Cutout..... 100 PSIG Reset
High Pressure .....	625 PSIG Cutout..... Manual Reset
Suction Operating Pressure .....	104 PSIG Low <sup>1</sup> ..... 145 PSIG High <sup>1</sup>
Discharge Operating Pressure .....	290 PSIG Low <sup>1</sup> ..... 600 PSIG High <sup>1</sup>
Subcooling @ approx. 80 °F ambient .....	10-12°F <sup>1</sup>

### **DIMENSIONS AND WEIGHT**

Height/Width/Length .....	Refer to Product Drawing
Approximate Weight .....	710 lbs.

\*Readings are dependent upon ambient conditions; numbers listed are approximate

Subject to change without notice.

# **HPKW5N4AS\* / HPKW5N\*AS\* – PRODUCT SPECIFICATIONS**

## **COOLING MODE**

Design Indoor Dry Bulb / Wet Bulb .....	<b>80°F / 67°F</b>
Design Outdoor Ambient Temperature .....	115°F
Total Cooling Capacity .....	BTU/HR..... 57,100
Sensible Cooling Capacity.....	BTU/HR..... 41,200
Minimum Indoor Ambient Temperature .....	65°F
Design Return Air Dry Bulb.....	80°F
Design Return Air Relative Humidity .....	50%
Approximate Supply Air Flow Rate .....	2000 CFM
Rated External Static Pressure .....	1.5" w.c.

## **\*HEATING MODE**

Heating Capacity .....	BTU/HR..... 55,700
------------------------	--------------------

## **POWER REQUIREMENTS**

Voltage / Phasing / Frequency.....	460/3/60
Minimum Circuit Ampacity Cool/Heat Unit.....	(Amps)..... 17.2
*Dehumidification Option.....	(Amps)..... 33.6
Max Overcurrent Protection.....	(Amps)..... 30
*Dehumidification Option.....	(Amps)..... 40

## **COMPRESSOR**

Type.....	5 Ton Scroll
Voltage / Phasing / Frequency.....	460/3/60
RLA.....	(Amps)..... 9.6
LRA.....	(Amps)..... 75

## **CONDENSER BLOWER MOTOR**

Horsepower .....	1.5
Voltage / Phasing / Frequency.....	460/3/60
FLA.....	(Amps)..... 2.7
Speed .....	RPM..... 3450

## **EVAPORATOR BLOWER MOTOR**

Horsepower .....	1
Voltage / Phasing / Frequency.....	460/3/60
FLA.....	(Amps)..... 2.5
Speed .....	RPM..... 3450

## **REFRIGERANT**

R-410.....	6 lbs. 9 oz.
Low Pressure.....	70 PSIG Cutout..... 100 PSIG Reset
High Pressure.....	625 PSIG Cutout..... Manual Reset
Suction Operating Pressure .....	104 PSIG Low <sup>1</sup> ..... 145 PSIG High <sup>1</sup>
Discharge Operating Pressure .....	290 PSIG Low <sup>1</sup> ..... 600 PSIG High <sup>1</sup>
Subcooling.....	@ approx. 80 °F ambient..... 10-12°F <sup>1</sup>

## **DIMENSIONS AND WEIGHT**

Height/Width/Length .....	Refer to Product Drawing
Weight .....	710 lbs.

\*Readings are dependent upon ambient conditions; numbers listed are approximate

Subject to change without notice.

The HPKW5N\*AS\* is a portable air conditioning unit designed for cooling of spaces such as tents, construction sites, and remote buildings. This product may also have optional electric heaters. If supplied with the electric heat option, refer to the specifications and operating sections provided for the electric heaters.

**IMPORTANT** – Read this instruction manual carefully before attempting to install, operate, or perform maintenance on this unit. This unit must be installed and maintained by qualified service technicians.

**WARNING:** BODILY INJURY CAN RESULT FROM HIGH VOLTAGE ELECTRICAL COMPONENTS AND FAST MOVING FAN DRIVES. FOR PROTECTION FROM INHERENT HAZARDS DURING INSTALLATION AND SERVICING, THE ELECTRICAL SUPPLY MUST BE DISCONNECTED. IF CHECKS MUST BE PERFORMED WITH THE UNIT OPERATING, IT IS THE RESPONSIBILITY OF THE TECHNICIAN TO RECOGNIZE THESE HAZARDS AND PROCEED WITH EXTREME CAUTION.

**NOTE:** “Warnings and Cautions” appear at the appropriate places throughout this manual. Your personal safety and the proper operation of this unit require that you follow them carefully. The manufacturer assumes no liability for installations or servicing performed by non-qualified personnel.

## UNIT INSPECTION

Upon receiving the unit, inspect for damage to the unit structural interior and exterior components that may have happened during transit. Immediately notify the carrier of damage to the unit. Verify the unit is the correct unit ordered by looking at the unit’s data plate. Figure 1

– Data Plate is located on the right hand side of the electrical box section. The main power source must be capable of delivering the required amount

of power to the unit. Refer to the installation instructions for connections.

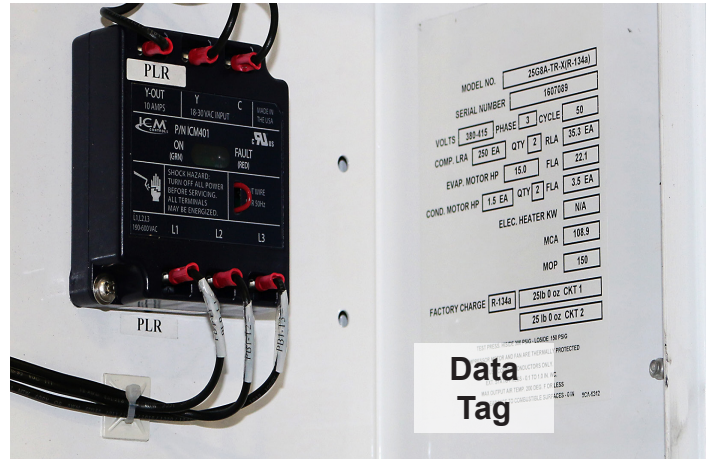

Figure 1 – Data Tag

## UNIT SETUP

### Location and Clearances

Select a location that permits unobstructed airflow into the condenser coil and out of the condenser fan discharge air outlet.

### Placement and Rigging

When using a forklift to set the portable air conditioning unit into place, ensure the forks are directly centered into the openings in the base frame of the equipment.

**CAUTION:** Use appropriate spreader bars and ties if lifting with a crane. **DO NOT LIFT BY HANDLES.**

### Pre-Installation Inspection

It is recommended that the following be inspected to insure internal components have not vibrated loose during shipment or transit from job site to job site.

1. Open the condenser blower/motor access panel. Check the condenser blower assembly, motor mounting hardware, pulley, belt, blower shaft, blower bearings, and blower wheel for proper tightness.

2. Open the evaporator blower/motor access panel located to the right of the control panel. Check the condenser blower assembly, motor mounting hardware, pulley, belt, blower shaft, blower bearings, and blower wheel for proper tightness.
3. Close and lock all panel doors.

### Electrical Connection

Refer to the unit data plate for main power requirements. Electrical wiring and grounding must be installed in accordance with The National Electrical Code NEC/NFPA Latest Revision. Refer to the electrical wiring diagram for Main Power connections also shown in Figure 2 – Camlock Power Connections which are located directly below the control panel. Unit may be configured with a variety of options.



**Figure 2A – Power Connections  
(Shown in Three Phase)**

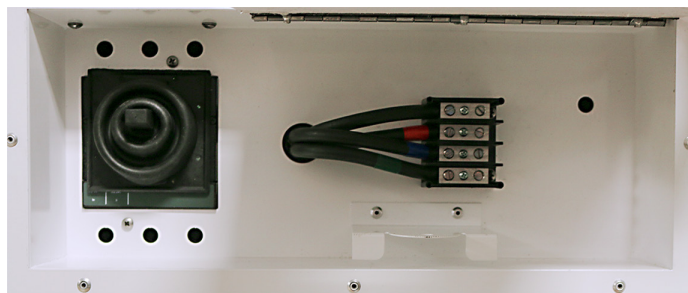

**Figure 2B – Power Block**

**CAUTION:** Only qualified electrical technicians should perform the electrical installation.

1. An envelope containing the electrical schematic is located in the electrical control box section for reference.

### NOTES:

1. Do not operate this unit if any of the voltage readings from line to line are more than  $\pm 10\%$  of the rated voltage.
2. Review the following steps to insure that electrical phasing and voltage setup is correct prior to initial start-up and unit operation. Single phase units require a voltage check and all three phase units require a check of both proper phasing and voltage.
3. On Three Phase Units, proper phasing of the electrical power wiring is critical for proper rotation of the motors and operation of the compressor. Electrical phase sequence monitors are standard on all three-phase 5 Ton Portable A/C units.
  - (a) Connect the power cable to the correct power source as verified by the unit's data plate shown in Figure 1 or also labeled at the Camlock connection fittings.
  - (b) Turn **ON** the main power to the unit.
  - (c) As soon as power is applied to the unit, check two items immediately.
  - (d) Read the voltage on the Voltage Meter.
  - (e) Next, verify the Red Out-of-Phase Indicator (OPI) (Three Phase Units) located on the front of the control panel is not illuminated as viewed from the control panel.
  - (f) At this point, **TURN OFF POWER** to the unit at the main power source.
  - (g) If the Red OPI light is illuminated, switch any two leads of the three main power wires connected from the main power source.

**CAUTION: Do not switch Green. Green is Ground.**



- (h) Turn main power **ON** again. When the Red OPI indicator light is off, the phase sequence is correct.
- (i) Turn **OFF** main power at this point and lockout the disconnect switch until the supply and return air ducting is connected.

## **DUCT CONNECTIONS**

### **Supply Air Duct**

The supply air duct connections are labeled “AIR OUT”. The connection size is 14" in diameter. Connect the flexible air ducting as follows:

1. Attach the flexible air ducting to the unit’s duct collars making sure that air will not leak past the connection collar by using appropriate round flexible ducting clamps.
2. Route the ducting as straight as possible to the space being conditioned avoiding excessive turns and pinches in the ducting.
3. Terminate the ends of each duct to the space being conditioned making sure that supply air does not have the possibility of short cycling back into the return air.
4. Verify the termination points are not restricted meaning no objects are directly in front of the Supply Air Grille (termination).

### **Return Air Duct**

The Return Air duct connections are labeled “AIR IN”. Follow the same procedures as the Supply Air Duct Connections. If outdoor air is required for specific applications use only one (1) Air In duct collar to pull in fresh outdoor air. The other must be ducted to the return air from the space being conditioned. Determine which Return Air Duct will be connected and terminate the return air ducts to that particular duct collars.

---

**CAUTION:** Do not operate the unit without duct(s) attached to the return air side of the unit. If operated without duct(s), the evaporator blower motor overloads will cut out on thermal overload due to the motor operating higher than design Full Load Amperage.

---

### **Condensate Drain**

There are condensate drains on both sides of the unit. There are two drain connection options:

1. Drain to the ground. The drain line must be trapped and filled with water before operating the unit. Filling the trap with water prevents negative air pressure inside the unit cabinet from holding the condensate internal to the drain pan which may eventually overflow if a trap is not installed.

If drain to ground is not a desirable option, connect the drain to a suitable drainage point such as a storm drain using a hose. The hose must still have a form of trap to allow the water to drain. Fill the trap with water before operation to form an air seal.

Or

2. Install a condensate pump allowing the water to drain into the condensate pump then pumping it to the location of condensate disposal.

## **SYSTEM OPERATION**

### **Getting Started**

1. Connect the 5 Ton Portable Air Conditioning unit to the correct power source.
2. Turn power **ON** at the main power source.
3. For three phase units, verify the Red Out-of-Phase Indicator (OPI) is not illuminated.
4. Verify the applied power “Voltage” is within  $\pm 10\%$  of the specified voltage of the unit.
5. **Install and secure all access panels before operating the unit.**



**Figure 3 – Control Panel**

**FAN Mode**

Turn Selector Switch (SS) to the **FAN** position. The Evaporator Motor Contactor (CEM) will energize to start the Evaporator Motor (ME) and the Fan Indicator (FI) will illuminate. The Evaporator Fan will operate continuously in the Fan and Cool modes of operation. It will also operate continuously during optional Heat Mode.

**COOL Mode**

Turn the Selector Switch (SS) to the Cool position. If the Return Air Temperature “AIR IN” is greater than the Thermostat setting sensed by the thermostats temperature measuring bulb, the compressor contactor (CCR) will energize the Compressor (CR) and the Amber Cool Indicator light (CI) will illuminate. When the compressor energizes, condenser fan contactor (CCM) will energize and condenser fan motor (MC) will start. As soon as the return air temperature falls below the thermostat setting, the compressor and condenser motors are de-energized.

To stop the unit, turn Selector Switch (SS) to the OFF position.

**HEAT Mode (Electric Heat Option)**

If this is a heat pump system with optional electric heat, an additional toggle switch shall be provided for the Heat Mode to allow for Heat Pump Only, Electric Heat Only, and Heat Pump plus supplemental Electric Heat. The applied power must be capable of handling the load of the system. Set the toggle switch to the appropriate position.

Subject to change without notice.

Turn the Selector Switch (SS) to the Heat position. If the return air temperature is below the unit's thermostat setting, the heating contactor (CHT) will energize the Electric Heating Elements and the Amber Heat Indicator light (HI) will illuminate. As the return air temperature rises above the Thermostat's setting, the heater(s) are de-energized.

To stop the unit, turn Selector Switch (SS) to the OFF position.

**REMOTE THERMOSTAT CONTROL – RTC (Option)**

These units are pre-wired for Remote Thermostat Control. When the remote thermostat is desired, insert the plug at the end of the cord into the unit's adapter located on the control panel side of the unit at the evaporator sections corner post. See Figure 4 – Remote Thermostat Connection below for location. After the plug has been inserted and properly tightened follow the procedures listed below:

- (a) Press the ON/OFF button shown in Figure 5 – Remote Thermostat Control. ON will display in the LCD. To turn off, press the ON/OFF button again and OFF will appear on the LCD.
- (b) Press the (+) or (–) sign and the Digits on the LCD will flash. Press and (+) to increase the temperature set point. Press the (–) to decrease the temperature set point.



**Figure 4 – Remote Thermostat Connection**



**Figure 5 – Remote Thermostat Control**

- (c) Press the SELECT button and adjust the COOL/HEAT setting using the (+,-) to the COOL mode.
- (d) Press the SELECT button again and adjust the fan to Continuous Mode using the (+,-). Using continuous fan mode will allow for more accurate readings at the temperature sensor.

## **UNIT SAFETY DEVICES**

### **Evaporator Motor Overload**

The evaporator and condenser motors are protected by thermal overloads. The evaporator blower motor protection is internal and automatically resets once the temperature inside the windings of the motor falls below the temperature trip point.

### **Condenser Motor Overload**

The condenser blower motor is external and protected manually with an overload block. This overload block is tied directly to the condenser motor contactor (CCM). This is a manual reset overload. If the condenser motor for any reason should cut out on overload, disconnect power using the unit's circuit breaker then open the main control box. Press the reset button on the CCM overload block. Refer to the troubleshooting guide section for information on troubleshooting.

### **High Pressure Switch**

The compressor system has a manual reset High Pressure Switch. If the unit is not providing cooling as evidenced by the Return Air Temperature "AIR IN" being approximately equal to the Supply Air Temperature "AIR OUT", the compressor system may have tripped on high refrigerant pressure. Disconnect power using the unit's circuit breaker. Remove the Access Panel to the Compressor Compartment and locate the Manual Reset High Pressure Switch. Press the button downward to verify if the switch tripped. If the button clicks the unit tripped on high pressure. Replace the access panel then reapply power using the unit's circuit breaker.

Set the unit to Cool Mode. Refer to the Troubleshooting section for causes and corrective actions. It may require a service technician to check system pressures if the switch trips more than 1-2 times.

### **Low Pressure Switch**

The compressor system has an automatic reset low pressure safety switch. If the unit trips on low pressure, the compressor will shut down but automatically restart once the switch resets. The low pressure switch shuts down the compressor system if the refrigerant pressure falls below 70 psig and automatically restarts the compressor once the pressure rises above 100 psig.

### **Compressor Internal Overload**

Each compressor has an internal motor overload switch. This switch opens to protect the compressor motor when the temperature within the windings of the compressor motor exceeds the high temperature trip point. When this switch opens, the compressor motor will continue to operate but the compressor pumping mechanism "scroll" will become disconnected. To reset this condition, the power must be disconnected from the compressor contactor. Set the unit back to the FAN position and allow the unit to operate in the FAN position for approximately 30- 45 minutes.

This should be enough time to cool the windings of the compressor motor which will allow the switch to reset (re-engaging the scroll). Set the Selector Switch back to COOL mode and the compressor should re-start. If this compressor goes out on internal overload condition, check the voltage. Since the compressor motor windings are cooled by the refrigerant gas as it enters the compressor, the unit may also be low on refrigerant.

## **UNIT COMPONENTS**

### **ELECTRICAL COMPONENTS**

#### **Contactors**

Contactors are used to energize the evaporator and condenser blower motors and compressor motor. Contactors have a set of high current carrying contacts for conducting line voltage to the load (device) and a magnetic holding coil which closes the line voltage contacts whenever control voltage of 24 VAC is applied by the control panel devices. The evaporator blower and compressor motors have built in internal overload protection to protect against high current draw. They automatically reset when the motors have cooled down.

#### **Defrost Control Board**

Should the Defrost Switch open to the Defrost Relay, the system shall start the defrost process. A defrost cycle shall be initiated 30 minutes from the time the defrost switch opens unless the defrost switch automatically resets during the defrost timing period. If the switch resets, the timing sequence is stopped.

The defrost cycle shall operating in defrost mode for 10 minutes or until the defrost switch resets. During the defrost cycle, the system will switch from heat pump mode to cooling mode to send hot gas into the condenser coil to warm up the defrost switch causing a reset. Typically the system should only be in cooling for a few minutes or less to cause the switch to reset so the amount of time in cooling will be very brief.

#### **High Pressure Safety Switch**

The high-pressure switch is designed to protect the compressor circuit from unusually high refrigerant pressures. If the refrigerant pressure rises above 600 PSIG, the pressure switch will open causing the compressor to shut off and the switch prevents it from re-starting until the manual reset button is pressed. Refer to the troubleshooting section for resolutions to the problem.

#### **Low Pressure Safety Switch**

The low-pressure switch is designed to protect the compressor circuit from unusually low refrigerant pressures. If the refrigerant pressure falls below 70 PSIG, the switch will open causing the compressor to shut off. As the pressure starts to rise above 100 PSIG, the switch will reset and allow the compressor to restart.

#### **Thermostat**

The unit has thermostat for one stage of cooling. Rotate the dial to set to the desired temperature set point.

## **REFRIGERATION SYSTEM COMPONENTS**

#### **Compressor**

The compressor is scroll hermetic type. The function of the compressor is to create a differential in refrigerant pressure. It converts low pressure, low temperature refrigerant vapor entering the suction side of the compressor into a high pressure, high temperature gas at the discharge side of the compressor. The function of the compressor also pumps the refrigerant through the piping and components within the refrigeration system.

#### **Condenser Coil**

The condenser receives the high-pressure high-temperature gas from the compressor after it passes through the vibration eliminator. As the condenser blower draws the ambient air across the fins and tubes of the condenser coil and

the high-pressure high-temperature gas enters the condenser coil, the gas starts to condense back into liquid state. At the outlet piping of the condenser coil, the gas has been turned back into liquid refrigerant and flows toward the receiver.

### **Evaporator Coil**

As the liquid refrigerant passes through the expansion valve, the liquid refrigerant's pressure is regulated downward. This significant change in pressure causes a drop in temperature of the refrigerant. When the warmer ambient air is drawn over the cooler evaporator coil, the warmer or latent heat is exchanged. As the heat is being exchanged, the exchange of heat energy causes the liquid refrigerant to boil into a vapor and greatly reducing the temperature of the air on the outlet side of the coil. The liquid refrigerant is converted into the lower temperature, lower pressure refrigerant causing it to changing into a vapor state.

### **Filter Drier**

The filter drier, filters loose particles, moisture and possible brazing residue from the system. If the unit starts tripping on low pressure cutout and the refrigerant line is frosted up to the outlet of the filter drier, check the refrigerant pressure drop across the filter drier and replace the filter drier if necessary.

### **Sight Glass**

A liquid sight glass is located before the liquid line solenoid valve. During the cooling mode of operation, pure liquid should flow through the liquid sight glass. The liquid refrigerant will appear clear enough to see the back of the inside of the sight glass. Flashing (bubbles) will appear in the sight glass during the first minute or two of operation until the expansion valve fully adjusts. If flashing is constant during the cooling mode, it may be an indication the unit is short of refrigerant. There may also be some flashing during hot gas bypass operation. See the Troubleshooting Chart for further details.

### **Reversing Valve**

The reversing valve reverses the flow of refrigerant causing the outdoor coil to become the cooling coil and the indoor coil to become the heating coil so that heat energy can now be provided to the space being conditioned.

### **Thermostatic Expansion Valve**

The expansion valve regulates the amount of liquid refrigerant entering into the evaporator. As the liquid enters into the expansion valve, the valve will start to change the state by changing the pressure of the liquid refrigerant as it passes through and starts to enter the evaporator coil. When the environments load conditions start to change, the bulb recognizes a change in temperature at the outlet piping of the evaporator to the suction side of the compressor and automatically adjusts the valve to maintain the correct flow into the evaporator coil.

## **ROUTINE MAINTENANCE**

To keep the Portable Air Conditioner operating safely and efficiently, it is recommended that a qualified service technician check the entire system at least once a year. Check the system more frequently depending on use and surrounding conditions.

### **Filters**

It is very important to keep the air filters clean. Be sure to inspect them at least once each month when the system is in constant operation. If the unit is equipped with disposable type air filters, replace them with the same type and size.

**NOTE:** Do not attempt to clean disposable air filters

### **Condenser Coil**

Inspect the condenser coil. If the condenser coil is dirty, clean with a stream of cold water, or pressurized air not exceeding 50 psig, or vacuum cleaner. Do not use hot water or steam, which can

cause excessive high pressure in the refrigerant system. Clean the condenser coil in the opposite direction of the airflow.

### Motor And Drive Components

Blowers and Motor bearings are pre-lubricated and sealed from serviceability. They do not require maintenance.

### Belt Tensioning

Excessive belt tension is the number one cause for blower bearing failure. Proper belt tension and pulley alignment are essential for trouble free operation. Insufficient deflection indicates that the belt tension is entirely too tight, and if not loosened somewhat, noise due to excessive vibration, premature bearing failure, shortened belt life, and a reduction in fan performance may result. Deflection is the amount the belt gives when force is applied, usually by finger, to the belt at the approximate center point to the belt span. Tight belts may also overload the motor and cause the efficiency drop considerably or even premature motor failure as well. Belt Span is the distance in inches between the drive shaft center point and the fan shaft center point. Refer to Figure 6 – Belt Tensioning.

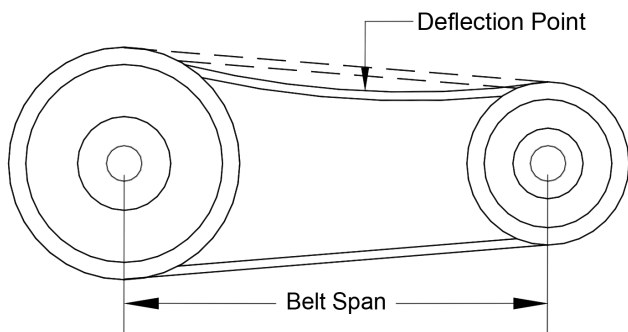

**Figure 6 – Belt Tensioning**

Excessive deflection is an indication that the belt is not tight enough. If not corrected, the belts will slip causing loss of blower speed, the belts will glaze due to excessive slipping and heat leading to premature belt failure. Belts may slip during start-up, but slipping should stop as soon as the fan reaches full speed. Please use the chart below for recommended deflection amount for the measured Belt Span.

Belt Span	Deflection Amount	Belt Span	Deflection Amount
12"	3/16"	36"	9/16"
15"	1/4"	39"	5/8"
18"	1/4"	42"	5/8"
21"	5/16"	45"	3/4"
24"	3/8"	48"	3/4"
27"	7/16"	51"	13/16"
30"	7/16"	54"	7/8"
33"	1/2"	57"	7/8"
36"	9/16"	60"	15/16"
39"	5/8"	63"	1"

Check the sheave alignment to make sure that the sheave faces are in the same plane. Check this by placing a straight edge across the face of the sheaves. Any gap between the edge and sheave faces indicates misalignment.

**CAUTION:** This method is only valid when the width of the surfaces between the belt edges is the same for both sheaves. When they are not equal or when using adjustable pitch pulleys, adjust so that the belts have approximately equal tension. Both shafts should be at right angles to the belt. Check the setscrew and/or bushing bolt tightness.

Belts tend to stretch somewhat after installation. Recheck belt tension after several hours of operation.

## PAC5N\*AS\* - Parts List

UCA Part #	Unit Description	Qty/Unit
19CA1069	Access Panel Latch, 1/4 Turn	16
8CA1008	Air Filter	1
5CA5012	Blower, Evaporator and Condenser	2
19CA11611	Camlock Cap, Black	1
19CA11614	Camlock Cap, Blue	1
19CA11613	Camlock Cap, Green	1
19CA11612	Camlock Cap, Red	1
19CA11601	Camlock, Black	1
19CA11604	Camlock, Blue	1
19CA11603	Camlock, Green	1
19CA11602	Camlock, Red	1
4CA1761	Circuit Breaker – Heater (Optional)	1
4CA1756	Circuit Breaker Weatherproof Boot	1
4CA1723A	Circuit Breaker, Control Voltage	1
4CA 1743	Circuit Breaker, Unit Main (208–230 V 3-Phase)	1
4CA1742	Circuit Breaker, Unit Main (460 V Unit)	1
2CAC05602D	Compressor (208–230 V/3/60 Unit)	1
2CAC05603D	Compressor (460 V Unit)	1
25CA1014	Compressor Electrical Harness (208–230 V 3-Phase)	1
25CA1015	Compressor Electrical Harness (460 V Unit)	1
2CA1001-1	Compressor Mounting Hardware (Optional)	1
13CA3117	Condensate Drain Plug	1
6CA6763	Condensate Drain Trap	1
1CA1728	Condenser Coil	1
4CA1082	Contactora, Compressor (208–230 V 3-Phase)	1
4CA1085	Contactora, Compressor & Electric Heat (460 V Unit)	2
4CA1059	Contactora, Condenser and Evaporator Motors	2
1CA1727	Evaporator Coil	1
6CA1031-3	Filter Drier	1
19CA1126	Grab Bar, Unit Movement	2
19CA1109	Handle, Unit Movement	2
4CA16033	Heater, Electric	3
4CA2319	Indicator Light, Amber	3
4CA2320	Indicator Light, Green	1
4CA2318	Indicator Light, Red	1
6CAC04051	Liquid Receiver	1

*Continued on Next Page*

### PAC5N\*AS\* - Parts List (Cont.)

UCA Part #	Unit Description	Qty/Unit
4RP2317	Mode Selector Switch	1
3CA1010	Motor Mounting Frame	2
4CA1075	Motor Overload, Condenser Motor (208–230 V 3-Phase)	1
4CA1073	Motor Overload, Condenser Motor (460 V Unit)	1
4CA1074	Motor Overload, Evaporator Motor (208–230 V 3-Phase)	1
4CA1072	Motor Overload, Evaporator Motor (460 V Unit)	1
3CA11211	Motor, Condenser	1
3CA1130-A	Motor, Evaporator	1
4CA1326	Power Block, Large, 175 Amp	1
4CA1327	Power Block, Small, 115 Amp (Optional)	1
11CA1192	Pulley, Condenser Blower	1
11CA1327	Pulley, Evaporator and Condenser Motors	2
11CA1105-2	Pulley, Evaporator Blower	1
4CA1284-1	Relay Base	3
4CA1284	Relay, 14 Pin	2
4CA12841	Relay, 8 Pin	1
4CA1265	Relay, Phase Monitor	1
6CA1040-3	Sight Glass	1
4CA1278-1	Switch, High Pressure Cutout	1
4CA1279-1	Switch, Low Pressure Cutout	1
18CA2002	Thermostat	1
4CA1105	Transformer, Unit Main Power to Control Voltage	1
11CA0052	V-Belt, Condenser	1
11CA0044	V-Belt, Evaporator	1
6CAC02001	Valve, Hot Gas Bypass (Optional)	1
6CAC01003	Valve, Thermostatic Expansion	1
70CA1610	Wheel/Caster, 8"	4

\*This chart is a generic list of parts/ contact the factory for unit specific parts verification



## TROUBLESHOOTING GUIDE

**WARNING:** BE AWARE OF HIGH POWER SITUATIONS WHILE TROUBLESHOOTING. THERE ARE ALSO MOVING BELTS, BLOWERS, AND MOTORS WHILE POWER IS CONNECTED TO THE UNIT. WHEN REACHING INTO ANY OF THE UNIT SECTIONS TO MAKE ADJUSTMENTS TO THE UNIT. PLEASE DISCONNECT POWER FROM THE UNIT.

Problem	Cause	Description
Power Lamp (PL) OFF	<ol style="list-style-type: none"> <li>1. No voltage to unit.</li> </ol>	<ol style="list-style-type: none"> <li>1. Check voltage at power supply and check for broken power wires.</li> </ol>
Power Lamp (PL) ON	<ol style="list-style-type: none"> <li>1. No cooling or no blower.</li> </ol>	<ol style="list-style-type: none"> <li>1. Check and/or replace defective selector switch.</li> <li>2. Check phase indicator light for correct phasing.</li> <li>3. Check for defective phase monitor.</li> </ol>
Unit Locked in Cooling Mode	<ol style="list-style-type: none"> <li>1. Thermostat incorrectly set.</li> <li>2. Defective thermostat.</li> <li>3. Defective compressor contactor CCR.</li> </ol>	<ol style="list-style-type: none"> <li>1. Check thermostat setting and selector switch mode.</li> <li>2. Replace thermostat.</li> <li>3. Replace compressor contactor CCR.</li> </ol>
No Cooling	<ol style="list-style-type: none"> <li>1. Dirty air filter.</li> <li>2. Check thermostat setting and mode selector switch.</li> <li>3. Defective power wiring to compressor.</li> <li>4. Defective compressor contactor CCR.</li> <li>5. Defective compressor motor</li> <li>6. Compressor won't start.</li> <li>7. Compression pressures almost equalized.</li> <li>8. Condenser motor tripped on overload may have also caused high pressure trip.</li> </ol>	<ol style="list-style-type: none"> <li>1. Clean or replace air filters in front of evaporator coil.</li> <li>2. Reset thermostat setting or mode selector switch.</li> <li>3. Check continuity of power wiring.</li> <li>4. Replace compressor contactor CCR.</li> <li>5. Check motor windings for shorts or opens and/or replace compressor if necessary.</li> <li>6. Internal overload opened up. Wait one hour to see if it resets and starts.</li> <li>7. Defective compressor valves. Replace compressor.</li> <li>8. Reset the overload and also check and reset the high pressure switch if required.</li> </ol>
High Pressure Trips	<ol style="list-style-type: none"> <li>1. Condenser air inlet and/or outlets are restricted.</li> <li>2. High-pressure switch open but doesn't reset.</li> <li>3. Defective condenser blower motor.</li> <li>4. Defective condenser blower motor contactor CCR.</li> <li>5. System is over-charged or has non-condensibles.</li> <li>6. Condenser blower v-belts loose, slipping, or broken.</li> </ol>	<ol style="list-style-type: none"> <li>1. Re-locate unit to a place with unobstructed airflow.</li> <li>2. Replace high-pressure switch.</li> <li>3. Replace condenser blower motor.</li> <li>4. Replace defective condenser blower motor contactor CCR.</li> <li>5. Remove some refrigerant. If the high side pressure doesn't start to drop, recover the refrigerant and re-charge with fresh R-22 to correct system charge.</li> <li>6. Re-tighten or replace v-belts.</li> </ol>

*Continued on Next Page*

<p>Low Pressure Trips</p>	<ol style="list-style-type: none"> <li><b>1.</b> Supply and return air grills in space are restricted.</li> <li><b>2.</b> Dirty return air filter.</li> <li><b>3.</b> Low-pressure switch open and does not reset.</li> <li><b>4.</b> Defective evaporator blower motor</li> <li><b>5.</b> Defective evaporator blower motor contactor CEM.</li> <li><b>6.</b> System might be under charged check sight glass and perform leak checks.</li> <li><b>7.</b> Expansion valve is sticking or binding.</li> <li><b>8.</b> Filter drier is dirty or plugged.</li> <li><b>9.</b> Evaporator blower v-belts loose, slipping, or broken.</li> </ol>	<ol style="list-style-type: none"> <li><b>1.</b> Re-locate objects in front of air grills or re-locate supply and return air grills in space.</li> <li><b>2.</b> Clean or replace air filter.</li> <li><b>3.</b> Replace low-pressure switch.</li> <li><b>4.</b> Replace evaporator blower motor.</li> <li><b>5.</b> Replace defective evaporator blower motor contactor CEM.</li> <li><b>6.</b> Recover refrigerant, repair leaks, re-leak check, evacuate and re-charge to system operating charge</li> <li><b>7.</b> Replace expansion valve.</li> <li><b>8.</b> Replace filter drier.</li> <li><b>9.</b> Re-tighten or replace v-belts.</li> </ol>
<p>No Condenser Blower Operation</p>	<ol style="list-style-type: none"> <li><b>1.</b> Tripped Condenser Motor Contactor Overload.</li> </ol>	<ol style="list-style-type: none"> <li><b>1.</b> Condenser blower motor moving too much air due to no blower ducting attached. Close off damper slide plate.</li> <li><b>2.</b> If access panels are off of unit, replace access panels.</li> </ol>

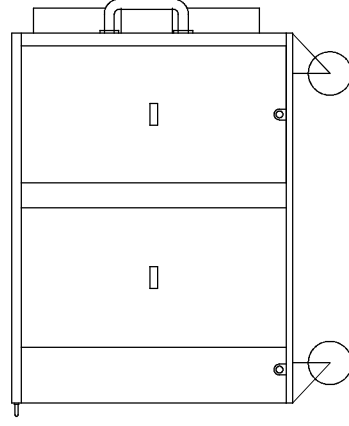
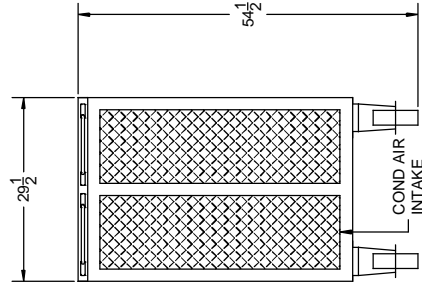
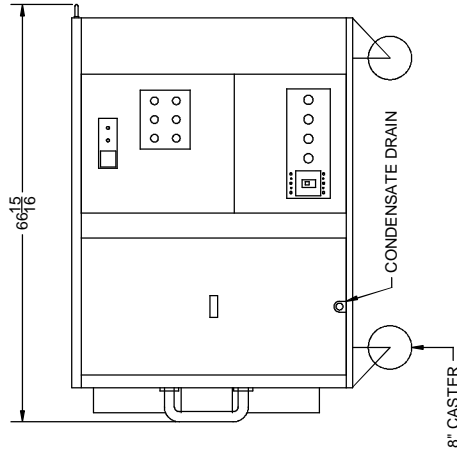
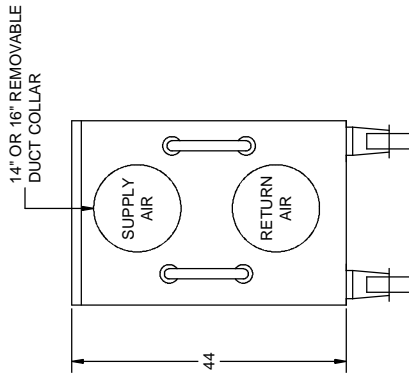
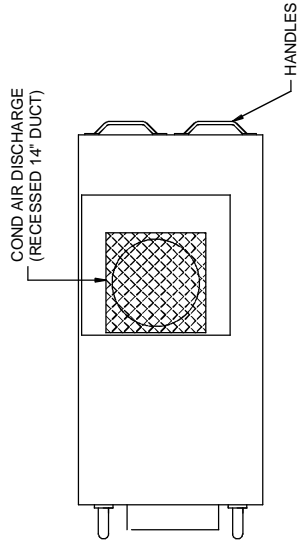

**SUBJECT TO CHANGE WITHOUT NOTICE**

**KOLDWAVE**

YORK, PA.

U.S.A.

ALL PROPRIETARY RIGHTS IN THIS PURCHASE ORDER/DRAWING ARE RESERVED. NO PERMISSION IS GRANTED TO REPRODUCE THIS DRAWING IN PART OR IN WHOLE, OR DISCLOSE ANY OF THE INFORMATION UPON IT TO OTHERS WITHOUT WRITTEN PERMISSION FROM KOLDWAVE.

TITLE:  
PHPH5N  
HEATPUMP  
HEATPUMP/HEATING

DWN BY: JTP

DATE: 01/18/12

APP. BY: JTP

SCALE: NOT TO SCALE

SHT: 2 OF 2

REV. DESCRIPTION

REV.	DESCRIPTION	BY	ECN#	DATE
B	REVISED MODEL NUMBER	JTP		11/4/13
A	ADDED SHEET 2	JTP		01/20/12
-	NEW	JTP		01/18/12

DWG. NO: CA14085

REV. LEV. B